

Clarke®



SHOT BLAST CABINET

MODEL NO: CSB20B

PART NO: 7640110

USER INSTRUCTIONS



UK
PA | CE

ORIGINAL INSTRUCTIONS

DL0524- REV 7

INTRODUCTION

Thank you for purchasing this CLARKE Shot Blast Cabinet which is designed for professional workshop use.

Before attempting to operate the cabinet, please read this manual thoroughly and carefully follow all instructions given. In doing so you will ensure the safety of yourself and that of others around you, and you can also look forward to the product giving you long and satisfactory service.

Carefully unpack the unit, and check against the list on page 3 to ensure that no damage was caused in transit. Should any damage be apparent, please contact your Clarke dealer immediately.

FEATURES

The 3 cu/ ft cabinet is lit by a low voltage (12 volt, 4 watt) 500 Lumens LED light, fed from a plug-in type transformer. The switch-box is mounted on the left side of the cabinet. The transformer should be plugged directly into the mains supply and connected to the switchbox which contains an ON/OFF rocker switch.

Air is extracted via a double filtration system at the right hand side of the cabinet.

Please note that when vacuum extraction is used, air will be drawn into the cabinet through the hole on the back panel of the unit. The hole is covered on the outside with a filter plate and housed within the plate is a foam filter, which must always be in place. This is to prevent grit from being blown out, when vacuum extraction is **NOT** used.

The lid is provided with a double clear plastic window, the inner of which may be renewed quickly and easily if it should become damaged by the media blasting action.

A variety of abrasive nozzles is supplied with the unit to produce a useful range of power and grit densities to satisfy all requirements. The cabinet is designed for use with dry abrasives **ONLY**. We recommend Aluminium Oxide (for cleaning steel) and Glass Beads (for cleaning aluminium).

It is necessary to provide a clean, dry air supply, capable of delivering a minimum of 10 cuft/min at a maximum 100psi. Please consult your air compressor manual, ensuring you comply with all safety precautions for the use of air compressors and observe all necessary precautions when using compressed air.

INVENTORY

Remove all components from the carton and check them against the following list.

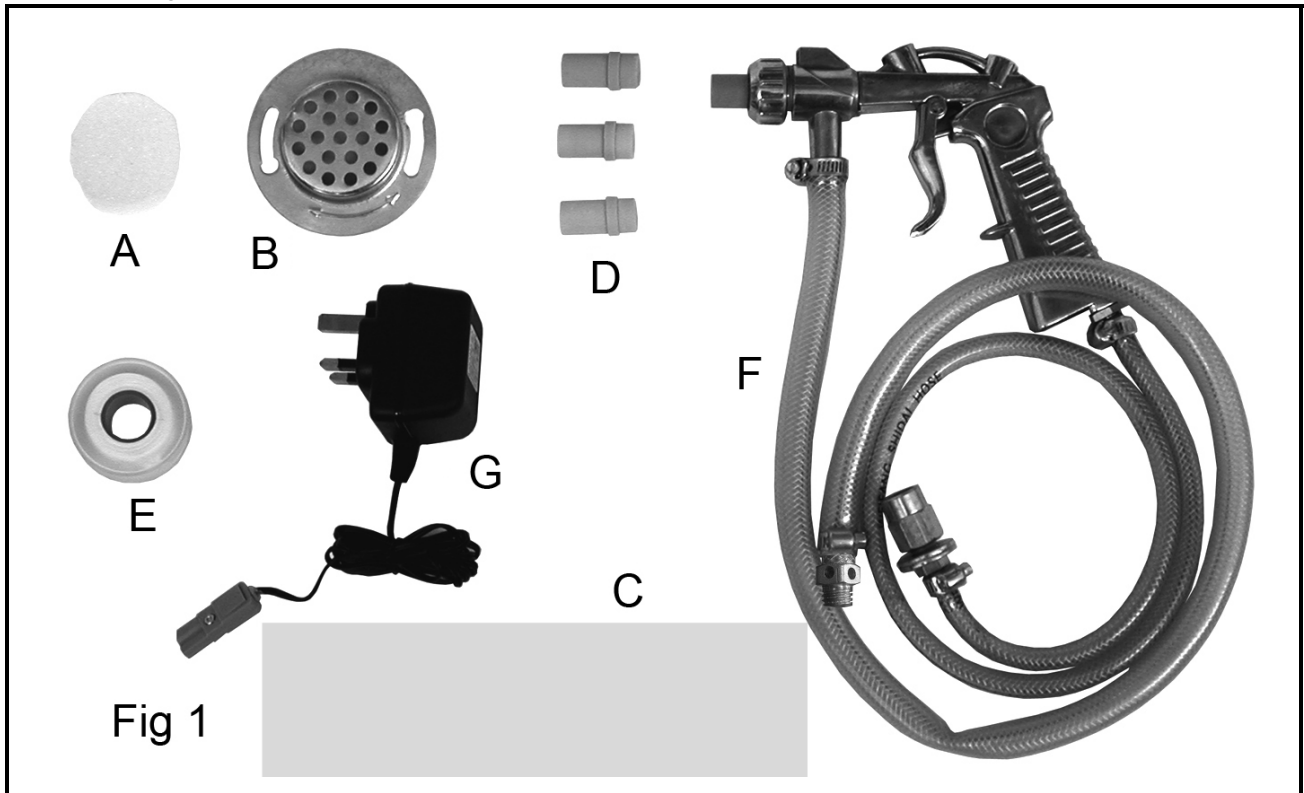

Fig 1

A - Foam Vent Filter

B - Air Vent Cover

C - 9 x Spare protective film

D - Ceramic Nozzles 4, 5, 6 & 7mm (one nozzle is fitted)

E - PTFE tape

F - Gun c/w air and pickup hoses

G - 12V transformer & cable

ASSEMBLY

The unit is shipped fully assembled, except for the air vent filter and the gun with attached hoses. These should be connected as follows:

First, remove the grid and all the various loose components from within the cabinet.

The end of the air inlet hose, connected to the gun, is inserted through the 16mm dia. hole in the cabinet from the inside, as shown in Fig 2. Ensure a flat washer is threaded on to the adapter as shown.

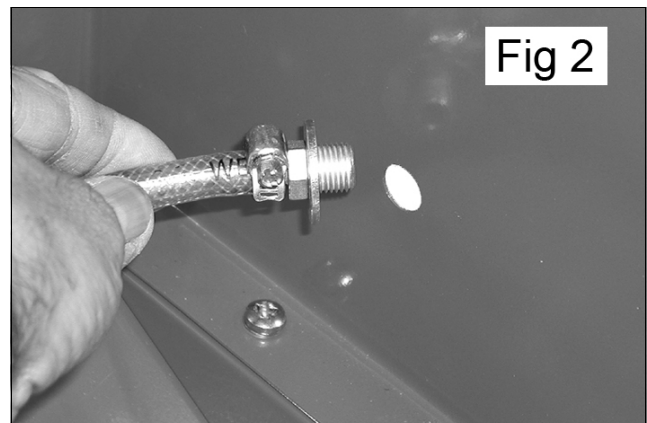

Thread a flat washer, followed by the extended nut, onto the adapter, from the outside of the cabinet, and tighten.

Insert the circular foam filter into the recess in the Air Vent Cover, and attach the cover to the rear of the cabinet as shown in Fig 3, having first prised out the plastic bung from the vent hole.

The pick up hose should be attached to the bottom of the cabinet as shown in Fig 4, using the large washer and nut underneath.

Replace the grid, ensuring the feet face downwards with the cut away section at the rear of the cabinet.

Finally, connect the air supply to the extended nut shown in Fig 5. Use of the PTFE tape supplied with ensure an airtight seal.

- The air supply should be dry and capable of delivering a minimum of 10 cu ft/min at 100 lbf/in.

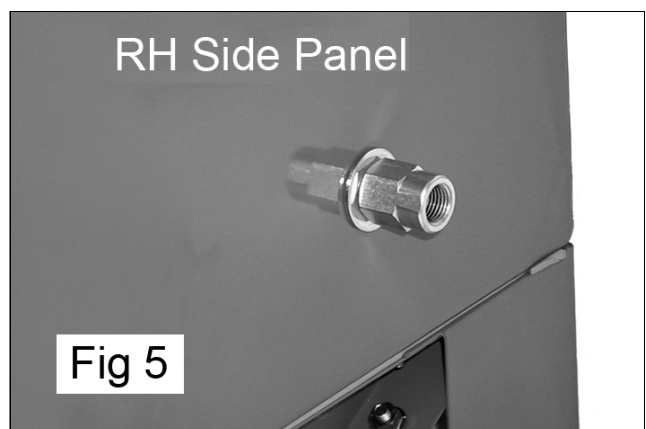
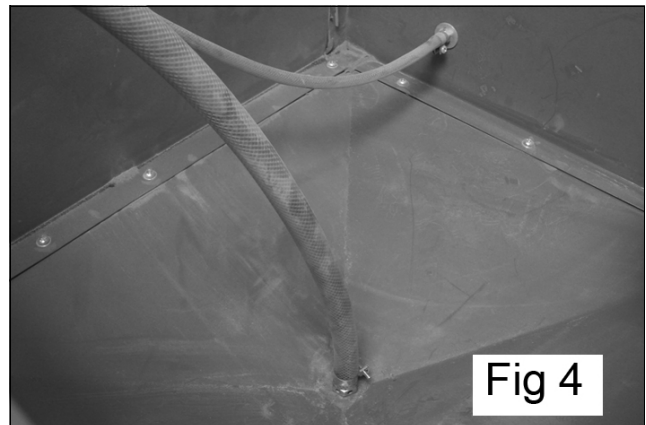

SAFETY PRECAUTIONS

Ensure you comply with all precautions regarding the use of air compressors and compressed air equipment.

- Ensure all air connections are secure.
- **DO NOT** use the machine if the integral gloves are ripped or unserviceable.
- Keep the jet well away from the air hose, gloves, light tube & window.
- Ensure the clear plastic lid is firmly secured before pressing the trigger.
ALWAYS wear safety glasses. (Normal eye glasses are **NOT** safety glasses).

- **DO NOT** use any silica based abrasives with this cabinet. Silica based abrasives have been linked to severe respiratory disease. Always use recommended abrasives. Abrasives used in this unit may be covered by COSHH Regulations.

OPERATION

Plug the transformer into the power supply and switch the power ON. Switch the light ON by pushing the rocker switch on the switch box 'I'. Switch OFF by pushing 'O'.

Ensure all air connections are secure, and the pick up is correctly located beneath the grid, before filling the cabinet with abrasive media. Do not fill higher than the level of the grid.

NOTE: PTFE tape is provided which may be used on the threads of the various connectors to ensure an airtight connection.

Select the ceramic abrasive nozzle to produce the jet required for the abrasive media being used, and assemble according to the instructions given below.

Place the object to be cleaned in the cabinet, and close the lid, securing with the two swivel clips.

Set the pressure to the required value, but not higher than 100lbf/in², and check to ensure there are no air leaks. Should there be any, turn off the air supply and repair where necessary, before turning the supply back on. Pull the trigger on the gun and proceed to blast the object to be cleaned.

Keep the jet facing the object and away from the clear plastic lid. Do not allow the jet to train on the rubber gloves, the air hose within the cabinet or the fluorescent lamp.

When completed, release the trigger then turn off the air supply. As a precautionary measure, **ALWAYS** pull the trigger before opening the lid.

- There are no hard or fast rules governing nozzle sizes and air pressures used with different abrasives. With experience and experimentation you will quickly learn the best combinations for the required result.
- On more delicate parts, start with minimal air pressure to avoid unnecessary peening or excessive abrasion, and work up to a setting to produce the desired finish.
- Should any abrasive be spilled, ensure it is cleaned up immediately, as its slippery properties can be hazardous.

REPLACING THE ABRASIVE NOZZLE

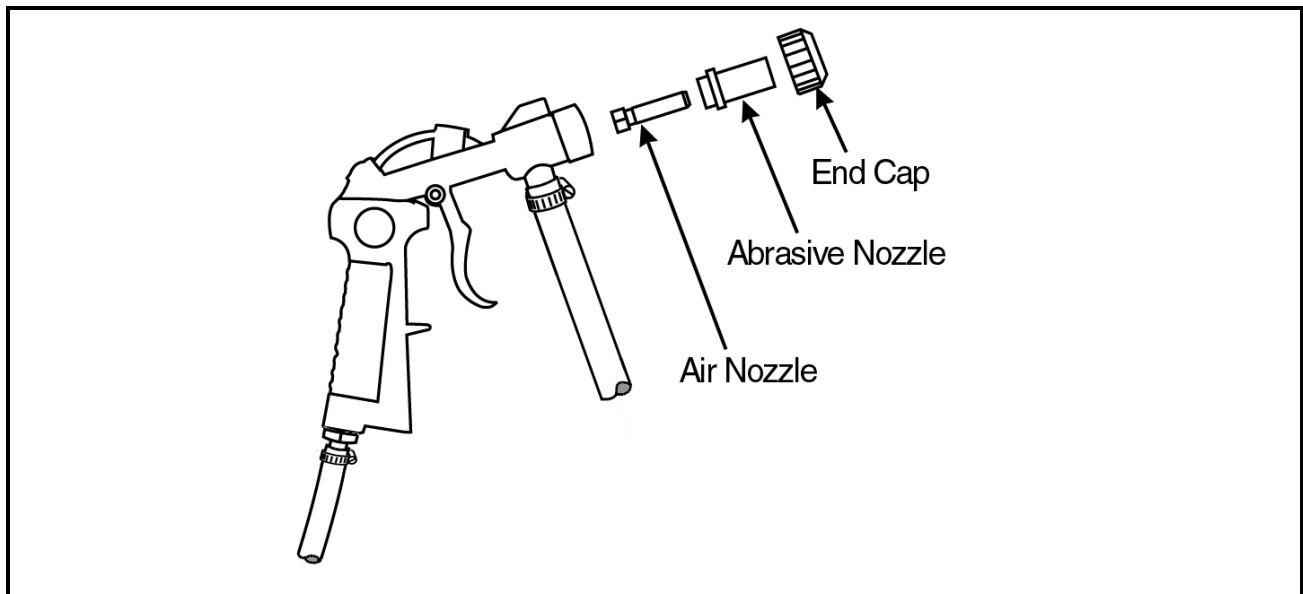

Ensure the air supply is disconnected before performing this operation.

1. Pull the trigger of the gun as a precautionary measure.
2. Unscrew the end cap and withdraw the ceramic nozzle.
3. Replace with the nozzle of your choice and carefully thread the end cap back on to the gun, taking great care NOT to cross thread the fine thread.

NOTE: Should it be necessary to change the air nozzle, first remove the abrasive nozzle as described above. A box spanner will be required to unscrew and withdraw the air nozzle.

MAINTENANCE

Before use, check to ensure that all parts are serviceable, including the air inlet hose and rubber gloves.

Ensure the air vent foam filter is in place.

The swivel clamps, securing the lid, must be secure so as not to allow the lid to open during operation. The build up of air pressure within the cabinet could force the lid open, allowing abrasive to escape. This is not only wasteful, but could be a health hazard.

Ensure the filters are serviceable and seated correctly.

Ensure you comply with all precautions regarding the use of compressed air, and air compressor operation.

GUARANTEE

This product is guaranteed against faulty manufacture for a period of 12 months from the date of purchase. Please keep your receipt as proof of purchase.

This guarantee is invalid if the product is found to have been abused or tampered with in any way, or not used for the purpose for which it was intended.

Faulty goods should be returned to their place of purchase, no product can be returned to us without prior permission.

This guarantee does not effect your statutory rights.

ENVIRONMENTAL PROTECTION



Recycle unwanted materials instead of disposing of them as waste. All unwanted accessories and packaging should be sorted and taken to a recycling centre for disposal in a manner which is compatible with the environment.

Through purchase of this product, the customer is taking on the obligation to deal with the WEEE in accordance with the WEEE regulations in relation to the treatment, recycling & recovery and environmentally sound disposal of the WEEE.

In effect, this means that this product must not be disposed of with general household waste. It must be disposed of according to the laws governing Waste Electrical and Electronic Equipment (WEEE) at a recognised disposal facility.

TROUBLESHOOTING

Problem	Check	Solution
Excessive dust in the cabinet.	No dust extract device used.	Install dust extract device.
	Air vent or overflow blocked.	Clean rear vent and keep vent away from any wall.
	Abrasive media worn.	Replace abrasive media
	Too much abrasive media in the cabinet.	Remove excessive media.
	Loose airline or loose connections.	Tighten fittings and ensure airline is secure.
Uneven blasting action	Too much abrasive media in the cabinet.	Remove excessive media.
	Abrasive is damp.	Renew abrasive or dry thoroughly before use.
	Moisture present inside cabinet.	Check airline to ensure it is free from moisture.
Inadequate speed or inefficient blast.	Abrasive media worn.	Replace abrasive media
	Pressure too low.	Increase inlet pressure and ensure control valve is fully open.
Static electricity present	Dry weather conditions.	Leave the item to be cleaned on the grid.
Excessive media blown into the surrounding atmosphere when no vacuum extract is being used.	Lid not secure.	Secure the lid with the swivel clips and adjust them if necessary.
	Air vent filter missing.	Replace filter or blank off hole in rear panel temporarily with masking tape.

DECLARATION OF CONFORMITY



Hennell Street, Epping, Essex CM16 4LG

DECLARATION OF CONFORMITY

This is an important document and should be retained.

We hereby declare that this product(s) complies with the following statutory requirement(s):

- Electrical Equipment (Safety) Regulations 2016
- Electromagnetic Compatibility Regulations 2016
- Pressure Equipment (Safety) Regulations 2016
- Supply of Machinery Regulations 2008
- The Restriction of the Use of Certain Hazardous Substances in Electrical and Electronic Equipment Regulations 2012

The following standards have been applied to the product(s):

- IEC 62368-1:2014, EN 62368-1:2014 + A11:2017, EN ISO 12100:2010, EN ISO 13849-1:2015, EN 60204-1:2018 + A1:2009 + AC:2010, EN 1248:2001/A1:2009, EN 61000-6-1:2007, EN 61000-6-3:2007 + A1:2011, EN 61000-3-2:2019, EN 61000-3-3:2013 + A1:2019, EN 1248:2001 + A1:2009, EN 55015:2019 + A11:2020, EN 61547:2009, EN 62321-4:2014 + A1:2017, EN 62321-5:2014, EN 62321-7-2:2017, EN 62321-6:2015, EN 63000:2018.

The technical documentation required to demonstrate that the product(s) meet(s) the requirement(s) of the aforementioned legislation has been compiled and is available for inspection by the relevant enforcement authorities.

The UKCA mark was first applied in: 2022

Product Description: Heavy Duty Blast Cabinet
Model number(s): CSB20B
Serial / batch Number: N/A
Date of issue: 25/07/2022

Signed:

J.A. Clarke
Director



Fitzwilliam Hall, Fitzwilliam Place, Dublin 2

DECLARATION OF CONFORMITY

This is an important document and should be retained.

We hereby declare that this product(s) complies with the following directive(s):

- 2014/35/EU Low Voltage Equipment Directive
- 2014/30/EC Electromagnetic Compatibility Directive
- 2014/68/EU Pressure Equipment Directive
- 2006/42/EC Machinery Directive
- 2011/65/EU Restrictions of the Use of Certain Hazardous Substances in Electrical and Electronic Equipment (RoHS) Directive

The following standards have been applied to the product(s):

- IEC 62368-1:2014, EN 62368-1:2014 + A11:2017, EN ISO 12100:2010, EN ISO 13849-1:2015, EN 60204-1:2018 + A1:2009 + AC:2010, EN 1248:2001/A1:2009, EN 61000-6-1:2007, EN 61000-6-3:2007 + A1:2011, EN 61000-3-2:2019, EN 61000-3-3:2013 + A1:2019, EN 1248:2001 + A1:2009, EN 12100:2010, EN 55015:2019 + A11:2020, EN 61547:2009, EN 62321-4:2014 + A1:2017, EN 62321-5:2014, EN 62321-7-2:2017, EN 62321-6:2015, EN 63000:2018.

The technical documentation required to demonstrate that the product(s) meet(s) the requirement(s) of the aforementioned directive(s) has been compiled and is available for inspection by the relevant enforcement authorities.

The CE mark was first applied in: 2017

Product Description: Heavy Duty Blast Cabinet
Model number(s): CSB20B
Serial / batch Number: N/A
Date of issue: 25/07/2022

Signed:

J.A. Clarke
Director

PARTS LIST

PART NO	DESCRIPTION
1	Steel Screen
2	LED Light Tube
3	Input Cable Assembly
4	Knob
5	Filter
6	Retaining Disc
7	Lid
8	Window Retaining Strip
9	Protective Film
10	Air Vent
11	Foam Filter
12	Plug Adaptor
13	Cable Transformer Box
14	Switch
15	Rubber Gloves (pair)
16	Clamp
17	Cable Clamp
18	Lid Swivel Clamp

PART NO	DESCRIPTION
19	Feet
20	Cabinet only (no lid)
21	Air Adaptor Nut
22	Lid Retaining Chain
23	Abrasive Pick-up Tube
24	Abrasive Intake Hose
25	Large Hose Clamp
26	Nozzle Adaptor Nut
27	Nozzle (4mm)
28	Gun Assembly
29	Air Hose Adaptor
30	Small Hose Clamp
31	Air Hose
32	Flat Washer
33	Screw M6 x15
34	Flat Washer
35	Steel Screw Bracket
36	Lamp Mains Adaptor

PARTS DIAGRAM

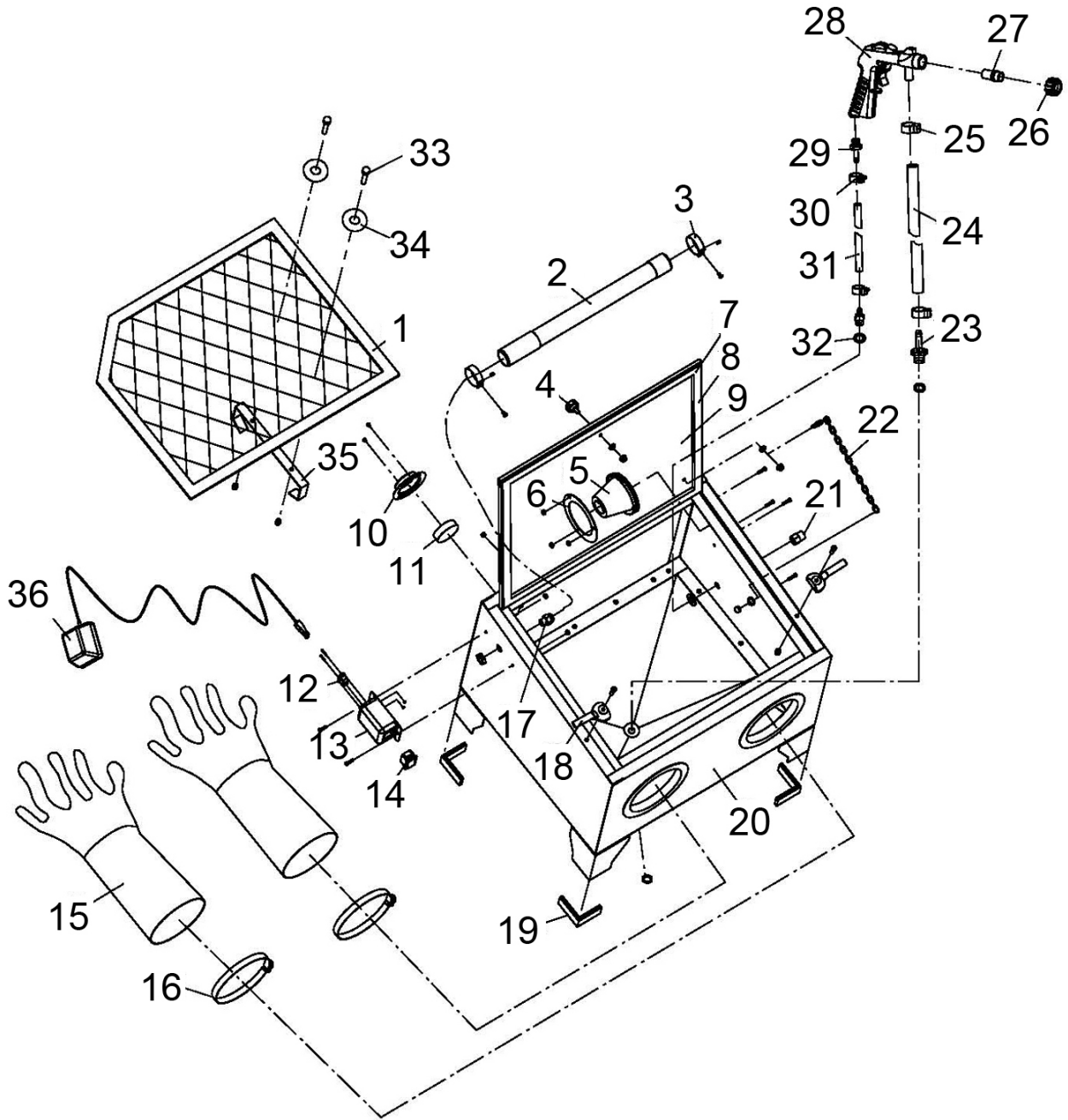

A SELECTION FROM THE VAST RANGE OF

Clarke®

QUALITY PRODUCTS



AIR COMPRESSORS
From DIY to industrial, Plus air tools, spray guns and accessories.

GENERATORS
Prime duty or emergency standby for business, home and leisure.

POWER WASHERS
Hot and cold, electric and engine driven - we have what you need

WELDERS
Mig, Arc, Tig and Spot. From DIY to auto/industrial.

METALWORKING
Drills, grinders and saws for DIY and professional use.

WOODWORKING
Saws, sanders, lathes, mortisers and dust extraction.

HYDRAULICS
Cranes, body repair kits, transmission jacks for all types of workshop use.

WATER PUMPS
Submersible, electric and engine driven for DIY, agriculture and industry.

POWERTOOLS
Angle grinders, cordless drill sets, saws and sanders.

STARTERS/CHARGERS
All sizes for car and commercial use.



PARTS & SERVICE: 0208 988 7400

Parts Enquiries
Parts@clarkeinternational.com

Servicing & Technical Enquiries
Service@clarkeinternational.com

SALES: UK 01992 565333 or Export 00 44 (0)1992 565335

Clarke® INTERNATIONAL Hemnall Street, Epping, Essex CM16 4LG
www.clarkeinternational.com